



Prijenos snage

- $\eta_p - D, n$
- direktan
 - krut: prirubnica ili kruta spojka
 - elastičan: elektromagn. i hidrauličke spojke
- indirektan
 - zupčani prijenos (97-99%)
 - električni prijenos



Reduktor

- prijenos snage pri različitim brzinama vrtnje, momentima i smjerovima
- prijenosni omjer: $i = n_1/n_2 = d_2/d_1 = z_2/z_1$
- trenje – gubici – podmazivanje
- cijena
- priprema pogona
- sigurnost poriva

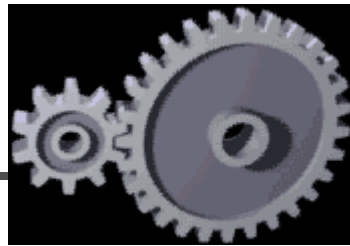
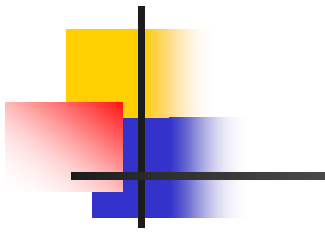

PLANET

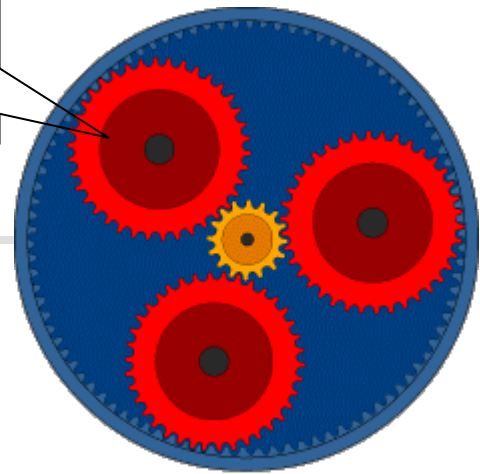

©2000 How Stuff Works

PLANET

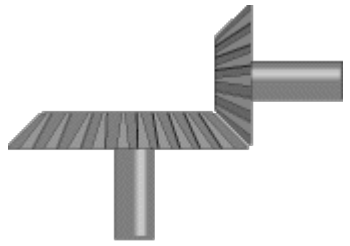

©2000 How Stuff Works

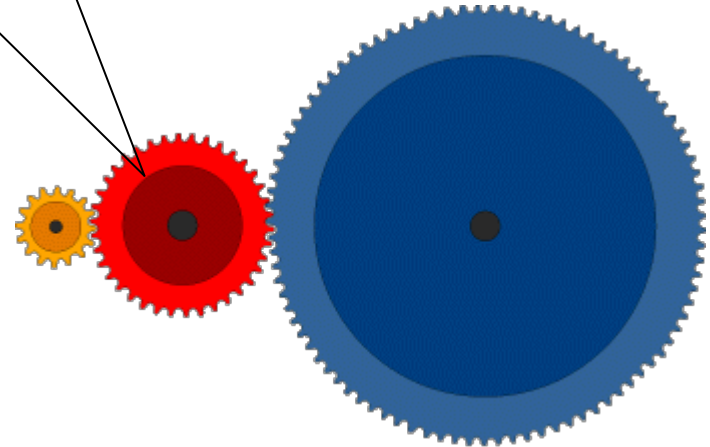

©2000 How Stuff Works

Ležajevi

- radijalni – nose vratilni vod
- aksijalni (odrivni) – preuzimaju porivnu silu stvorenu radom brodskog vijka
- klizni

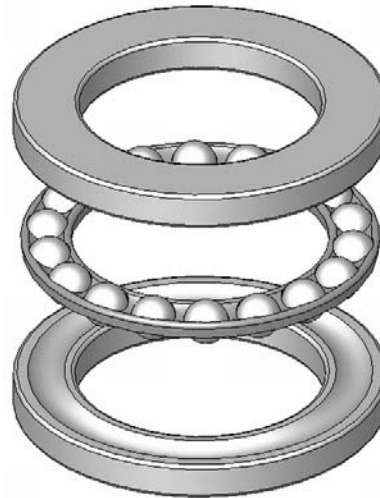

Propulzor

- brodski vijak
 - s fiksnim krilima
 - prekretni (prekretanje motora u nuždi)
- dr. izvedbe



PROPELER SA ZAKRETNIM KRILIMA

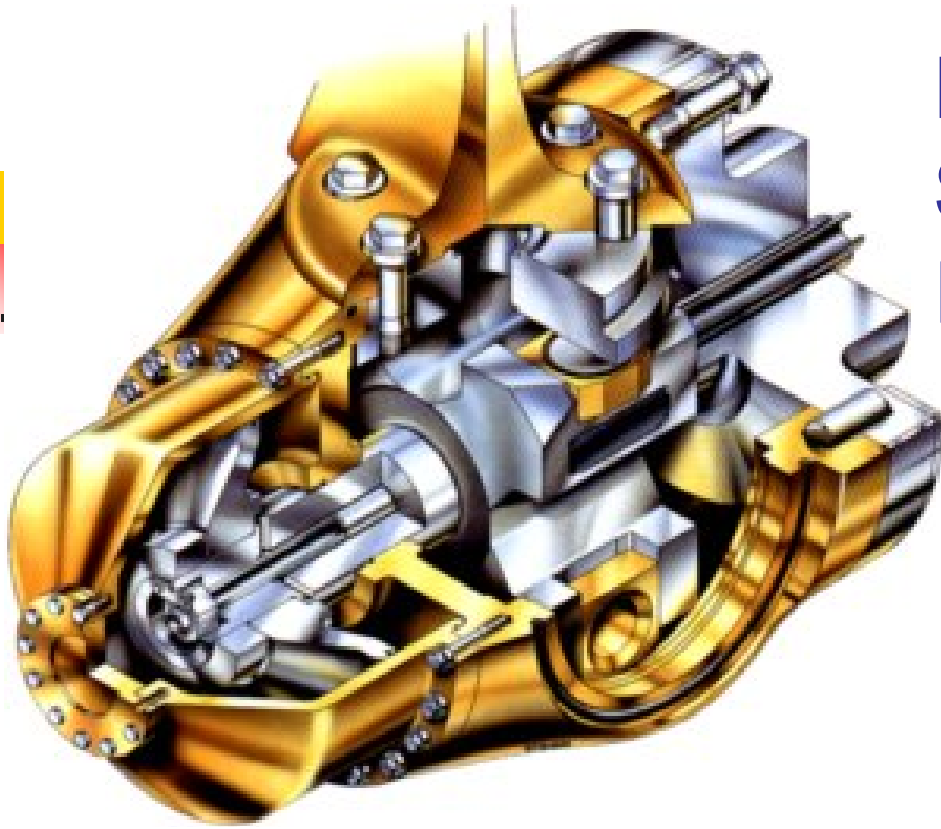

1. štiti propeler
2. usmjerava vodu
3. η poriva



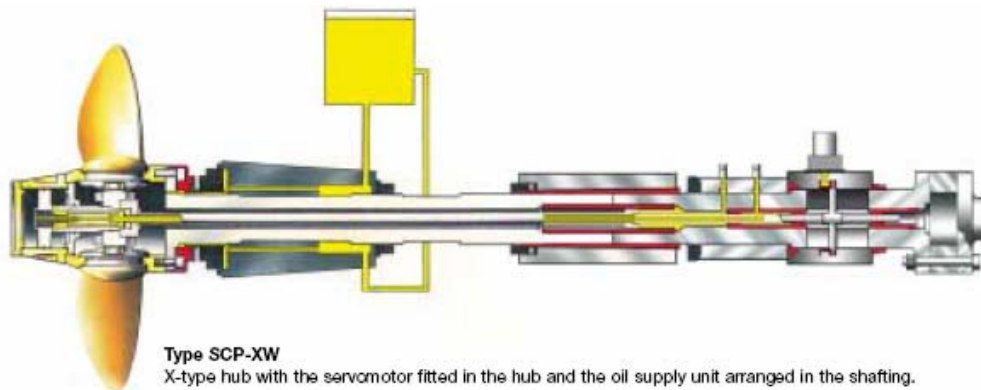
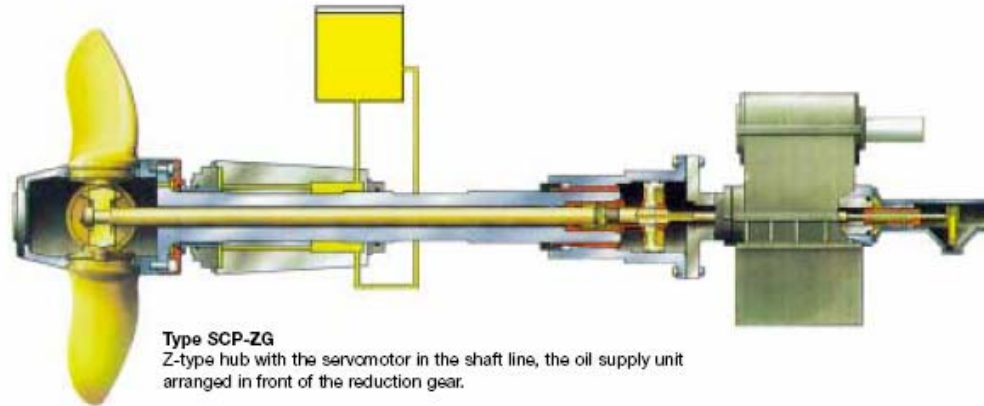



Slip ili skliz

- prividni ili stvarni
- odnos teoretskog gibanja vijka i brzine strujanja vode ili brzine broda

$$s_a = \frac{\frac{Hn}{60} - v}{\frac{Hn}{60}} [\%]$$

$$s_r = \frac{\frac{Hn}{60} - v_e}{\frac{Hn}{60}} [\%]$$



Mjerenje snage glavnog stroja

- na osovini: $P_s = M_t \cdot \omega$ $\omega = 2\pi \cdot n$
- torziometar $\tau = \frac{M_t}{W_p}; \tau = E \cdot \varepsilon \Rightarrow M_t = EW_p \cdot \varepsilon$
- optički
- DM: indikator
- DM: procesni

$$P_i = p_i \cdot \frac{D^2 \pi}{4} \cdot \frac{S \cdot n}{30} \cdot z \cdot \tau$$

Pokusna vožnja na mjernoj milji



- odnos v, P, n
- dokaz brodovlasniku
- procjena propelera
- daljnje praćenje broda
- budući projekti i modeli