



BRODSKI ENERGETSKI SUSTAVI

Sustav goriva, uputnog
zraka, podmazivanja...

Bregasta

© RART 2001

Damping
Pin

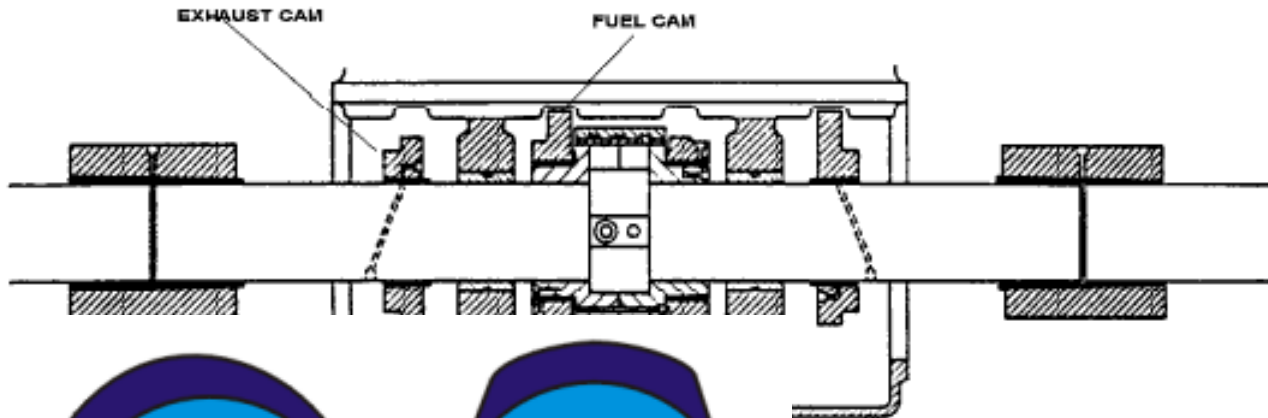

B:

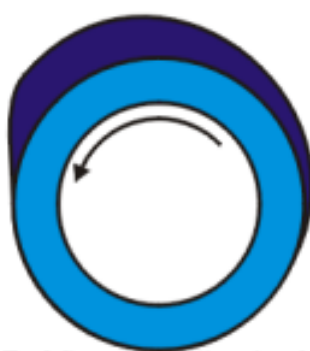

Fuel Cam for unidirectional medium speed engine. The cam has fast lift for injection and a slow return to avoid shock loading



Inlet or exhaust valve cam for unidirectional medium speed engine. The cam has to open and close the valve smartly without shock loading

3 SERVOMOTOR

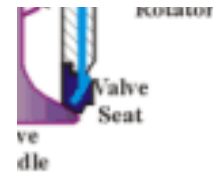

Usis/ispuh – 'klackalica'

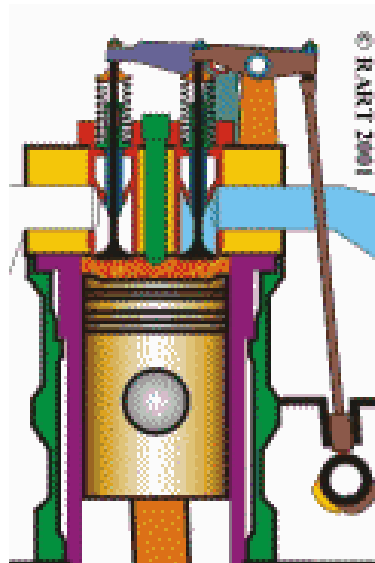



Ubrizgavanje goriva

- visokotlačni sustav
- direktno ubrizgavanje
- vrtložne ili pretkomore
- klipne pumpe
 - sa zakretnim klipom, VIT
 - s preljevnim ventilom
- ventili (rasprskачi)
- "common rail" sustav

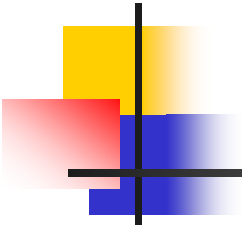

Regulacija dobave goriva: zakretanjem klipa

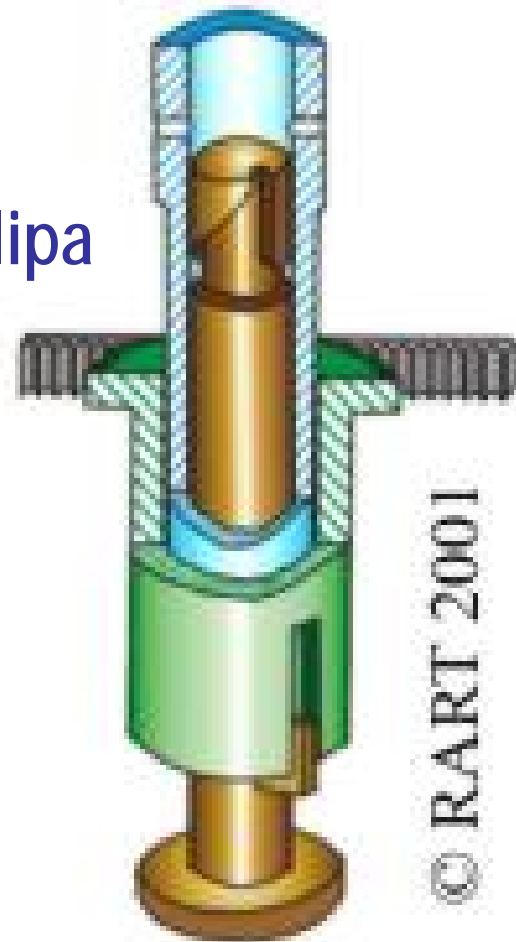
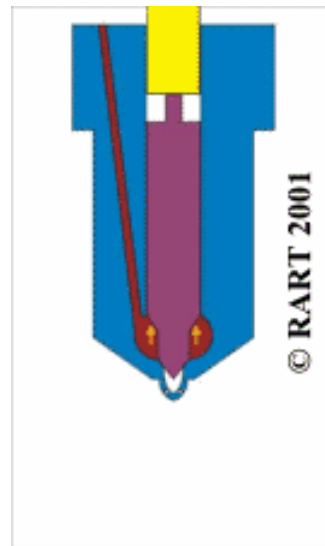
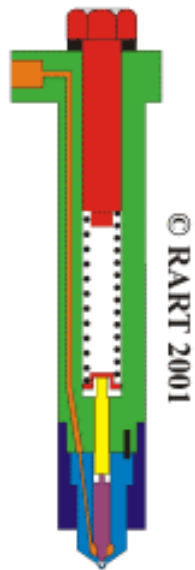

'Common rail'

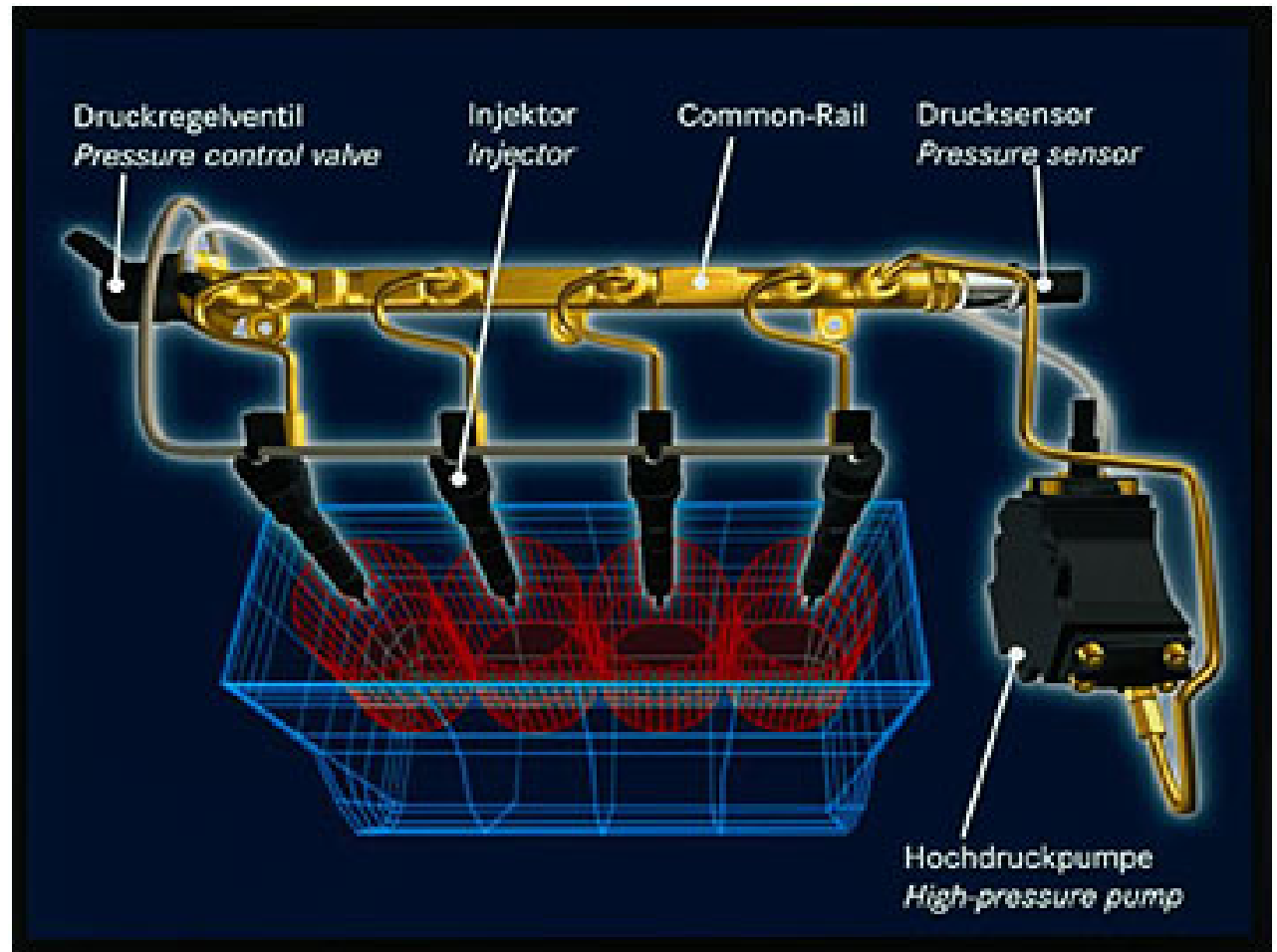



Podmazivanje

- manji motori privješene zupčaste p.
- veće snage – vijčane elektromotorne
- podmazivanje cilindara
 - “bućkanjem”, prskanjem
 - tlačno, lubrikatori
- eksplozija uljnih para! (indikator)

Otvaranje uputnog ventila

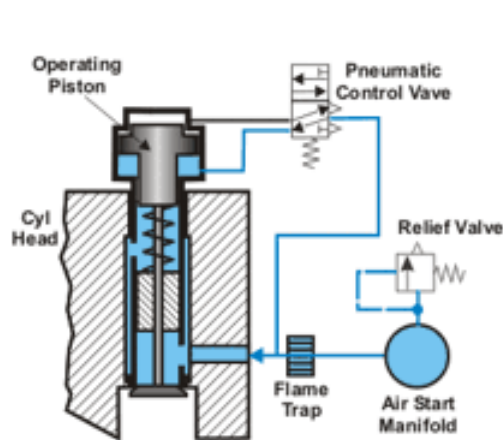

© 2003 RART marinediesel.co.uk

UPUTNI VENTIL
ZATVOREN

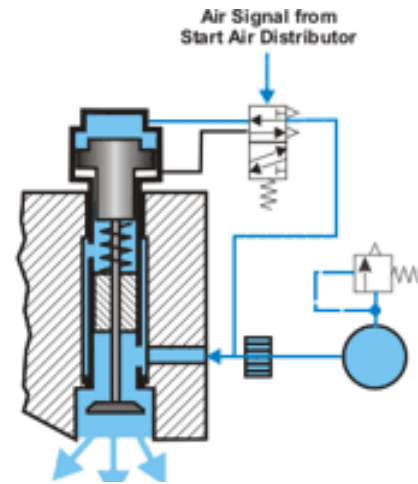

© 2003 RART marinediesel.co.uk

UPUTNI VENTIL
OTVOREN

Uputni (startni) zrak

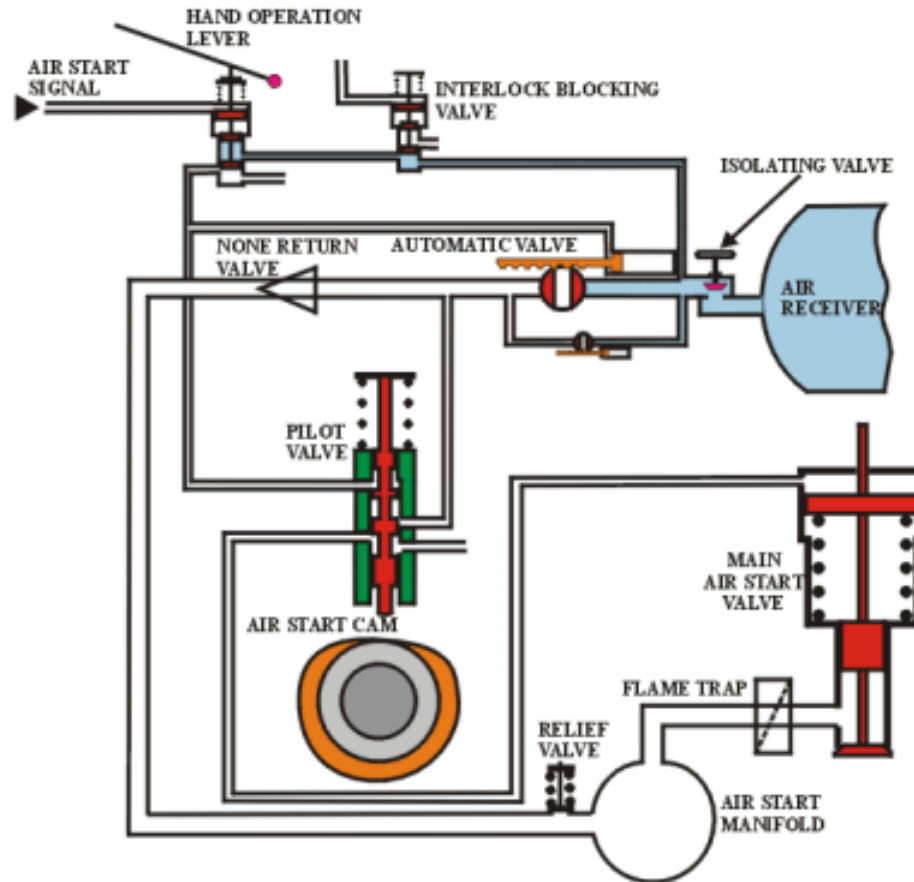

Upućivanje

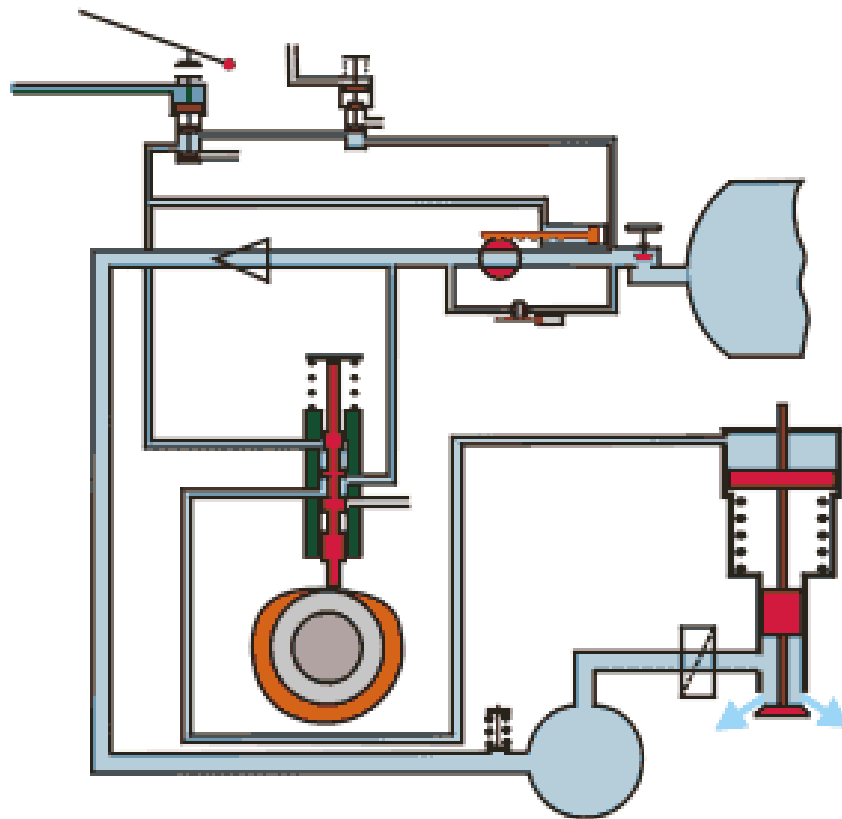

Prekretanje motora

© RART 2001

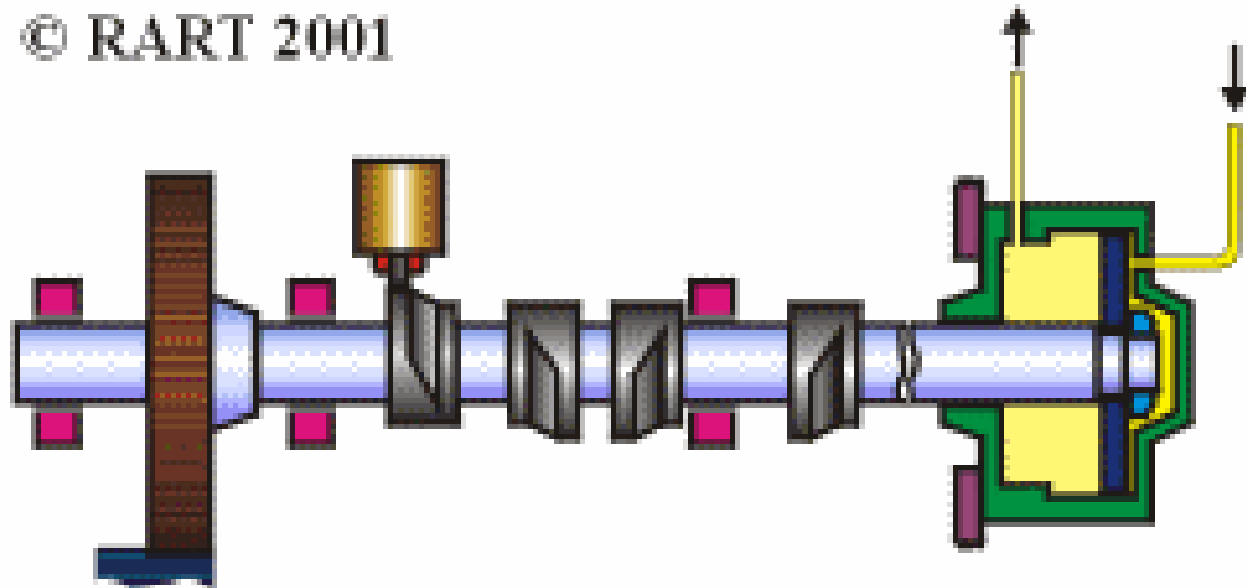

Regulator

- regulator broja okretaja
- “Woodward”
- (mehanički) hidraulički
- elektronski

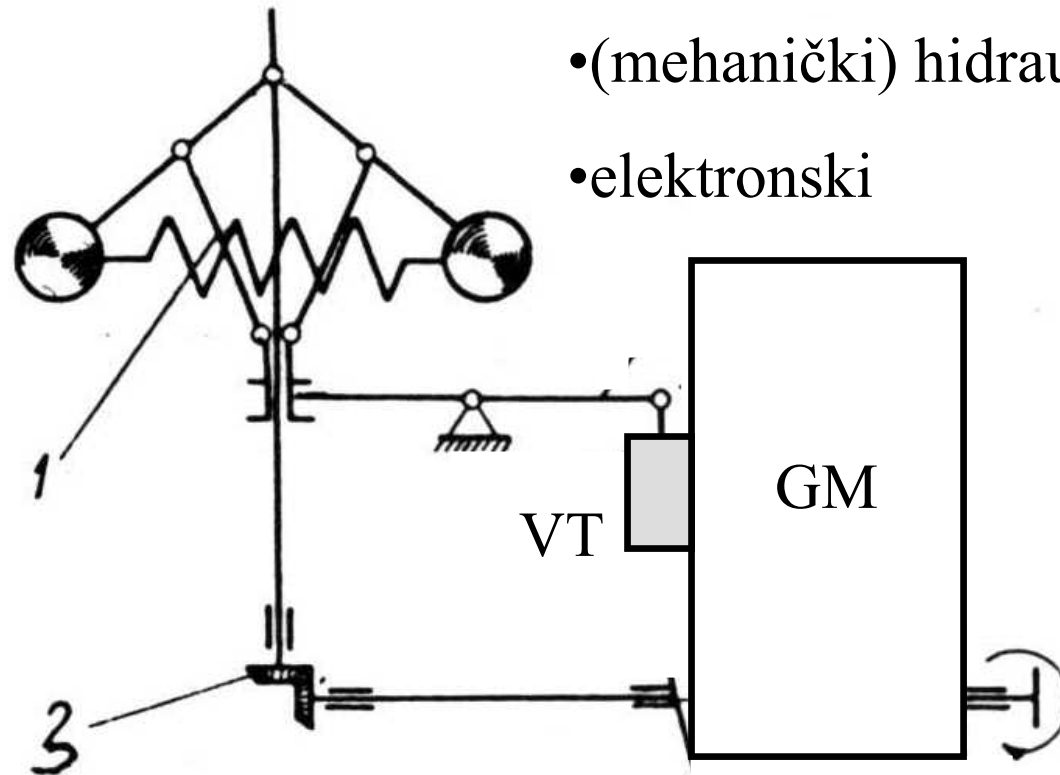

Požar u isp. prostoru

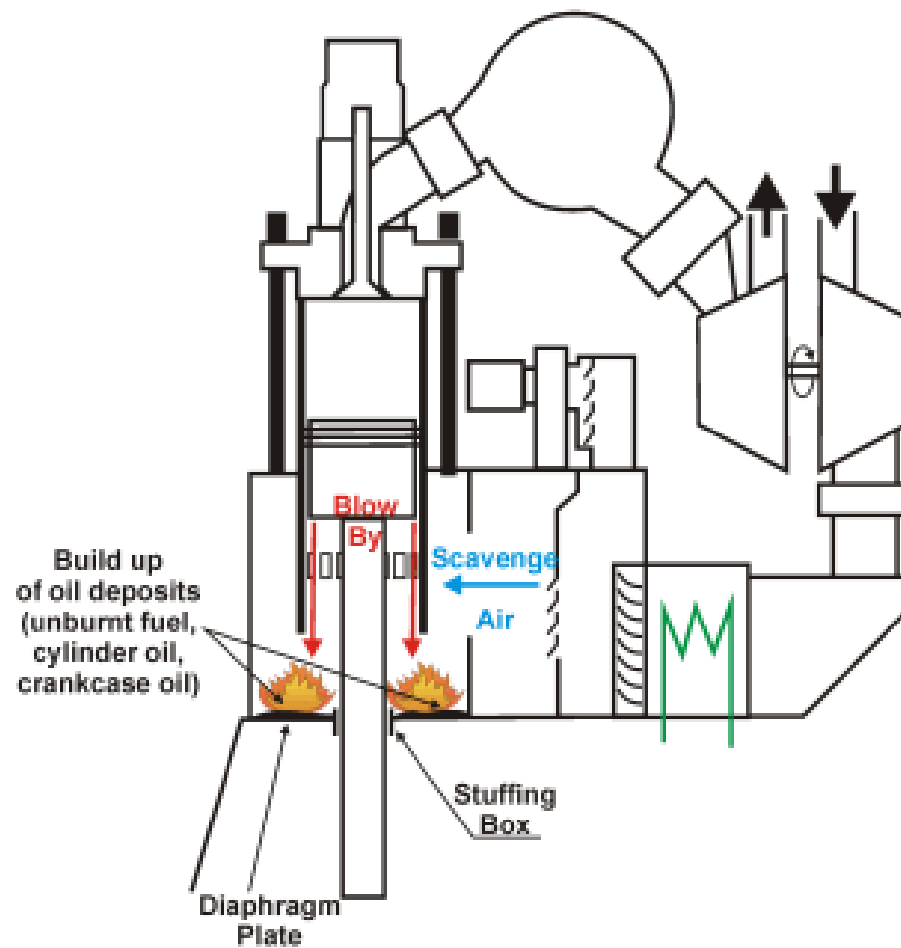

Uljne pare

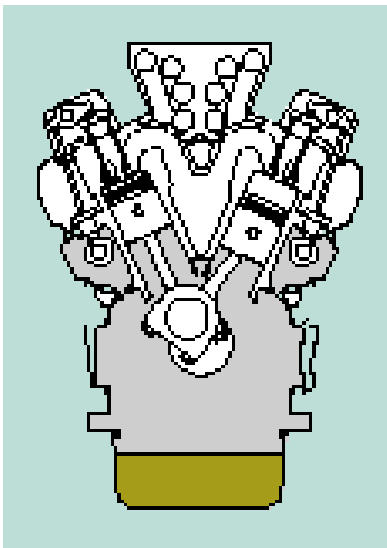

An unprotected engine – no Oil Mist Detector

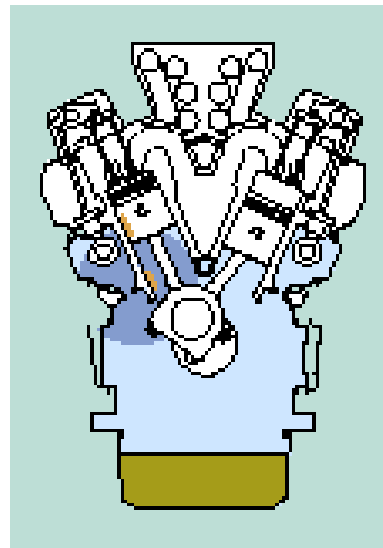

Build-up of oil mist due to 'hotspot' being undetected

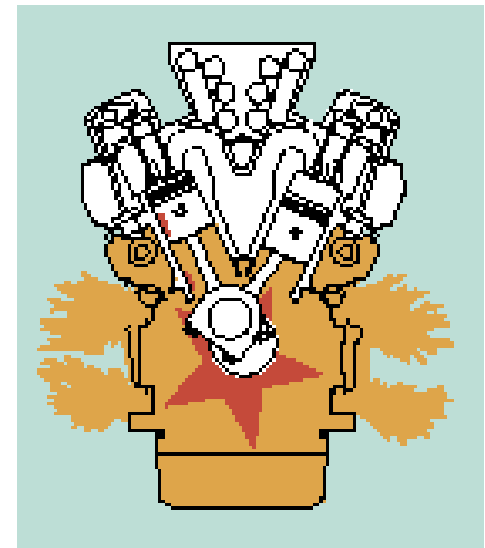

The possible result – ignition of oil mist causing a crankcase explosion

Gašenje

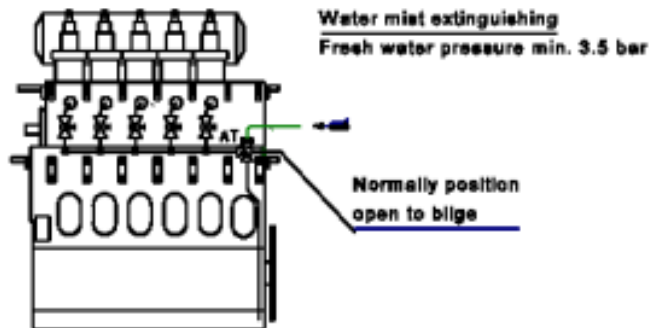
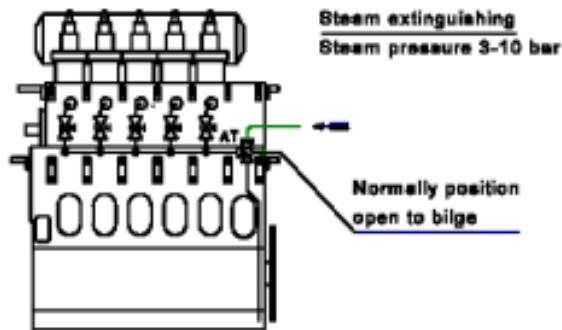

To prevent the fire from spreading to the next cylinder(s), the ball-valve of the neighbouring cylinder(s) should be opened in the event of fire in one cylinder

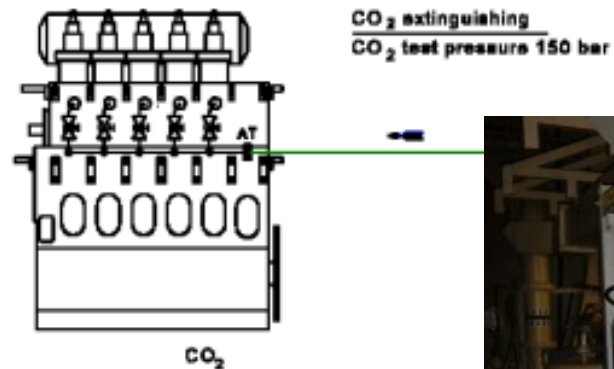

At least two bottles ought to be installed. In most cases, one bottle should be sufficient to extinguish fire in three cylinders, while two or more bottles would be required to extinguish fire in all cylinders

