

BRODSKI STROJNI KOMPLEKSI

Motori s unutarnjim
izgaranjem

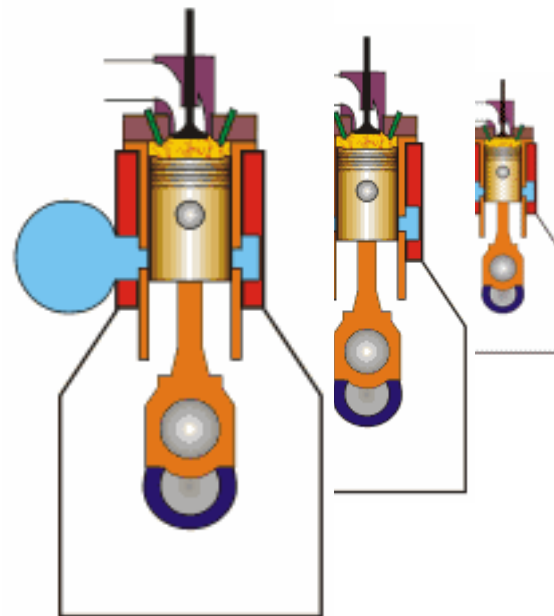

Komandni most

PRIPREMA UPRAVLJANJE ALARMIRANJE

Running | HD 110 | Main Engine – Bridge Control | Group

START AIR PRESS

PROPELLER SPEED

FUEL ECONOMY

SHIP SPEED

Finish with Engine | ECR Stand By | At Sea

Responsibility Transfer

Local | Engine Ctr. R | **Bridge** | Loss of Response

RESET

73.9 Actual | 74.0 Command

Fixed Speed Setpoint: 0.0

Propeller Pitch

Full | Half | Slow | Dead Slow | Stop | Dead Slow | Slow | Half | Full

Control lever: 100.0

Emerg Stop | **Fixed Pitch** | Combi | Econ | Fixed Speed

AST | COMMAND | AHD

CAMSHAFT POS

STOP SIGNAL | START SIGNAL

Shut Down | Slow Down | Fail

LO Press | LO Press | Start F

Th Bearing | Th Bearing | Rev Fail

Cyl Cool T | Pist Cool F | Brake F

Overspeed | Scav Air T | Start Air

Turn G In | Misc | Ctr Air

Auto Chief
Main Engine
Bridge Control

NavSim Connection

SHD Pre-warn.	SLO Pre-warn.	Therm. Load Progr.	Load Limits
SHD Over-ride	SLO Over-ride	Progr. Over-ride	Limits Over-ride

Sporookretni porivni

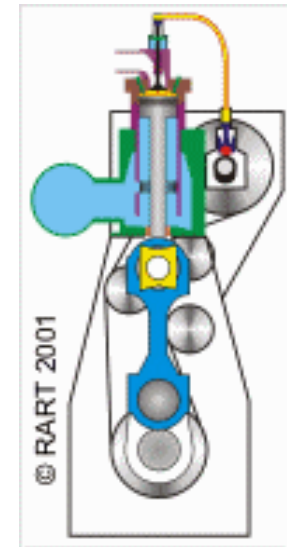
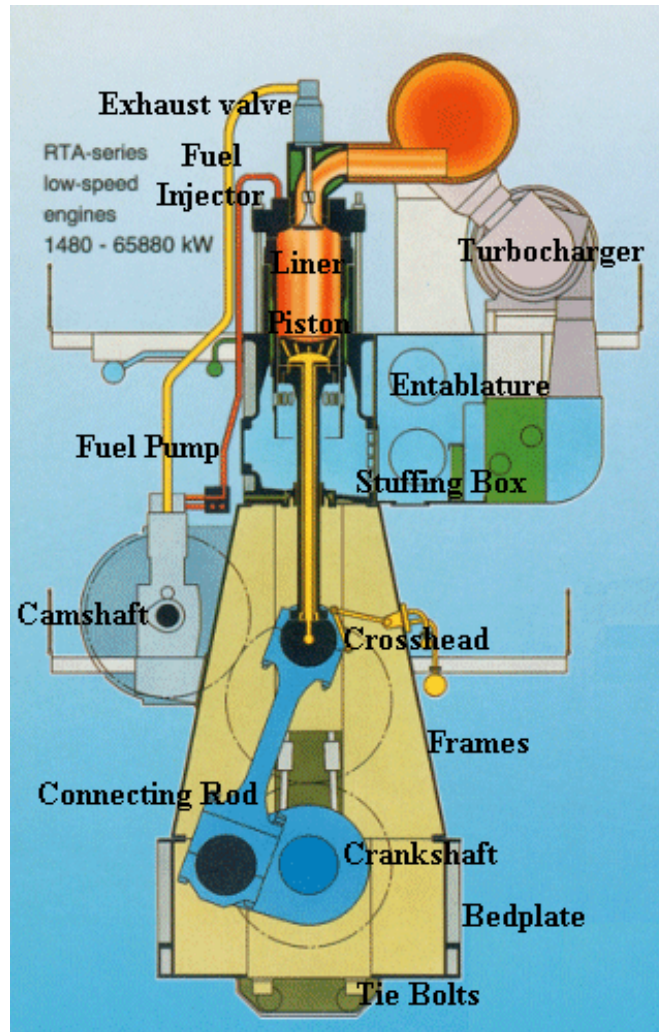

Startanje – 30% n_{nom}

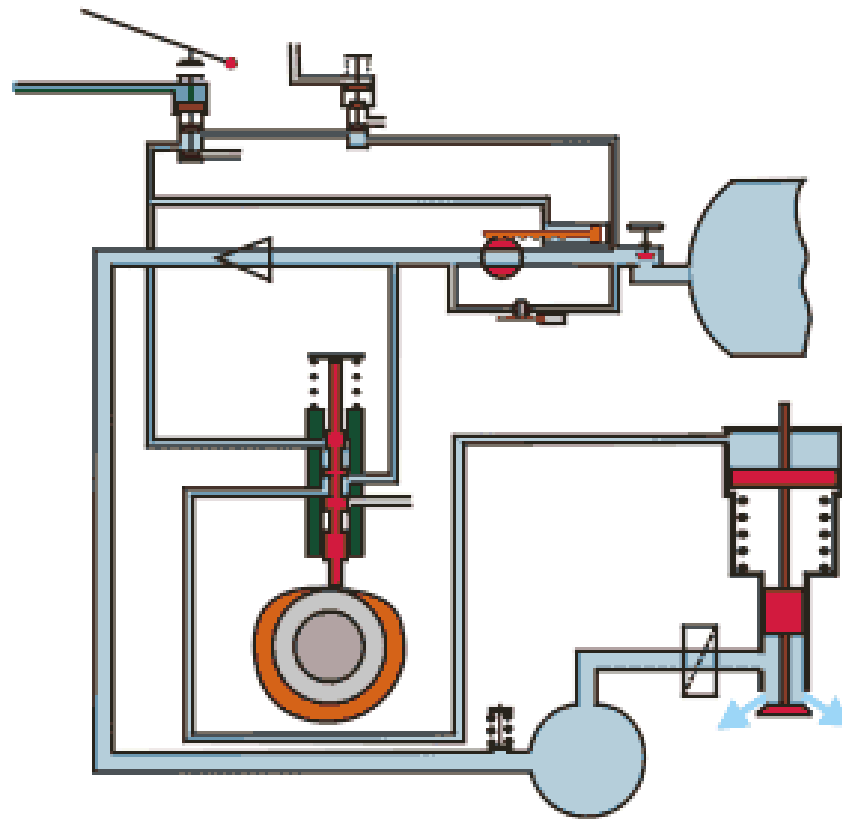

Podjela

Prema odvijanju radnog ciklusa	2^t ; 4^t
Prema načinu djelovanja	jednoradni ; dvoradni; s prot. st.
Prema vrsti goriva	tekuće ; kruto; plinovito; komb.
Prema punjenju cil. zrakom	s turbopunjenjem i bez
Prema prostoru izgaranja	s pretkomorom i bez
Prema konstrukciji	s križnom glavom i bez
Prema prekretanju	prekretni; neprekretni
Prema brzohodnosti (broju okretaja kolj. vratila)	sporo-, srednje- i brzookretni

Podjela

Prema namjeni (brodski)	porivni; za generatore...
Prema rasporedu cilindara	linijski; V; W; L; zvjezdasti...
Prema gibanju "stapa"	pravocrtno; okretno



Karakteristike

- 2^t (4^t)
- jednoradni
- tekuće gorivo (teško, ostatno, HFO)
- turbopunjenje (s konstantnim tlakom)
- bez pretkomore, direktno ubrizgavanje
- s križnom glavom (4^t - bez)
- prekretni / neprekretni
- sporookretni (srednjeokretni)
- linijski, V (W)

Karakteristike goriva

- Toplinska vrijednost 39000-42000 kJ/kg i više
- Gustoća (15°C)
- Viskoznost, viskozimetar
- Sadržaj S, V, Na
- Plamište
- Točka samozapaljenja
- Sadržaj vode
- Koksni broj (Conradson, Ramsbottom)
- CETANSKI i OKTANSKI broj

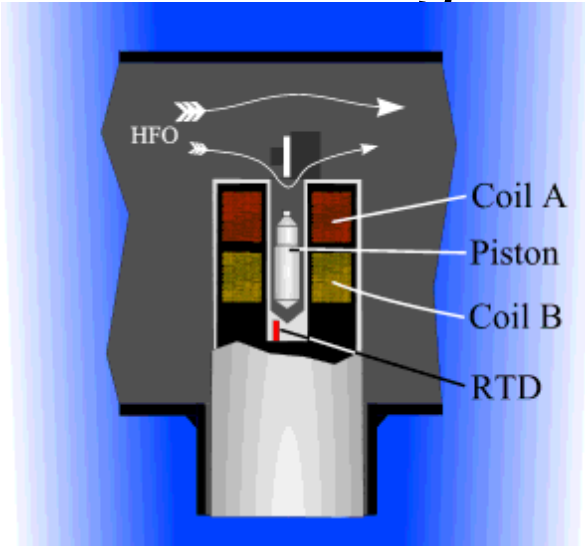



Izgaranje goriva

- sastav (h, c, o, n, s...)
- stehiometrijski odnos ($\approx 15 \text{kg}_z/\text{kg}_g$)
- pretičak λ ($=1,4 \dots 2,2$)
- pretičak ispiranja
- $\lambda = \lambda_{\text{izg}} \lambda_{\text{isp}}$ ($=1,8 \dots 3,3$)



Karakteristike maziva

- Gustoća
- Viskozitet (kinematički, dinamički)
- Indeks viskoznosti (IV)
- Aditivi: protiv pjenjenja, starenja, disperzanti...
- TBN



Benzinski : Dizelski

- 2^t i 4^t benzinski (Otto) motori
- dizelski 4^t motori
- priprema gorive smjese
- zapaljenje

Toplinski proces

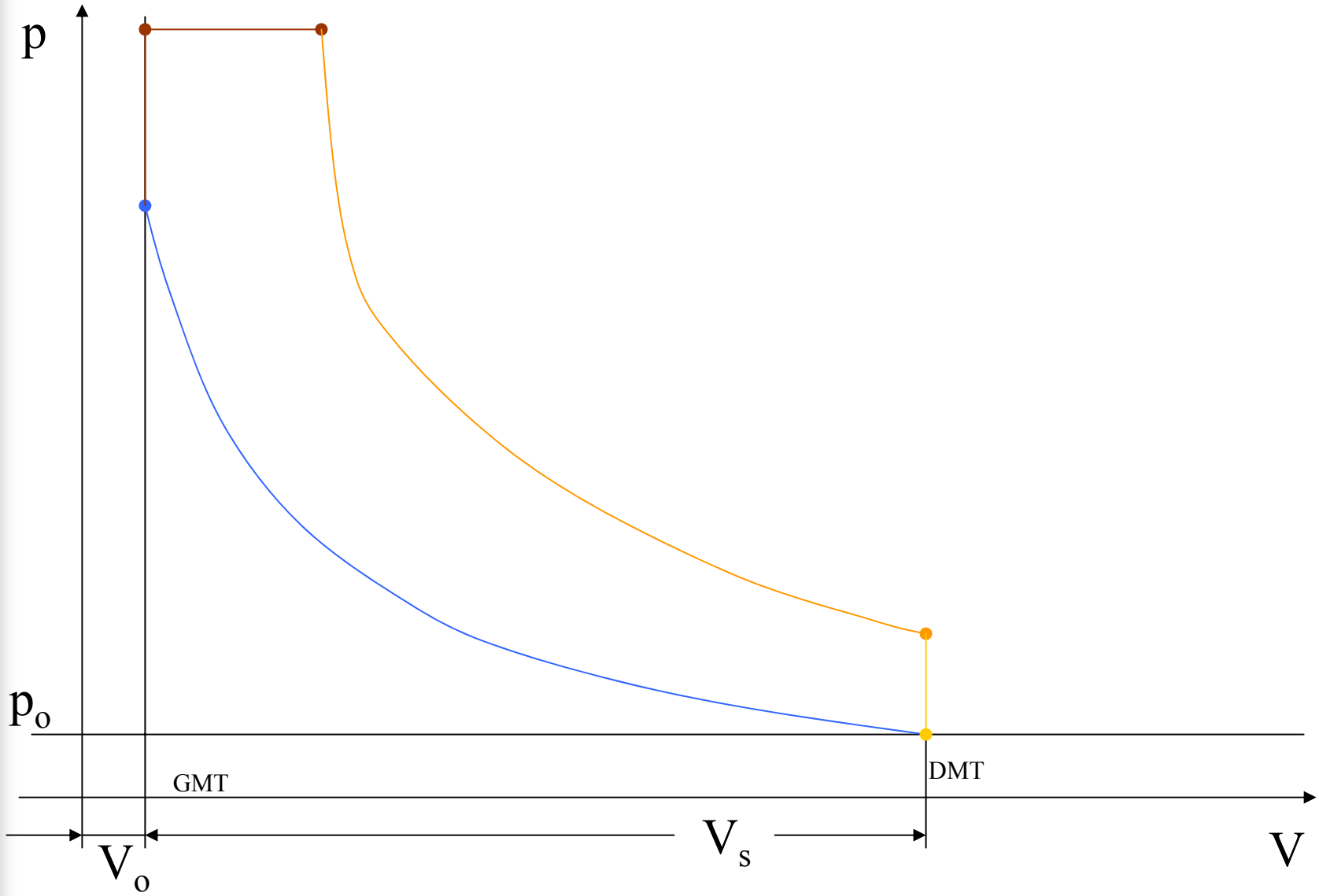

Izmjena radnog medija u 2^t motoru

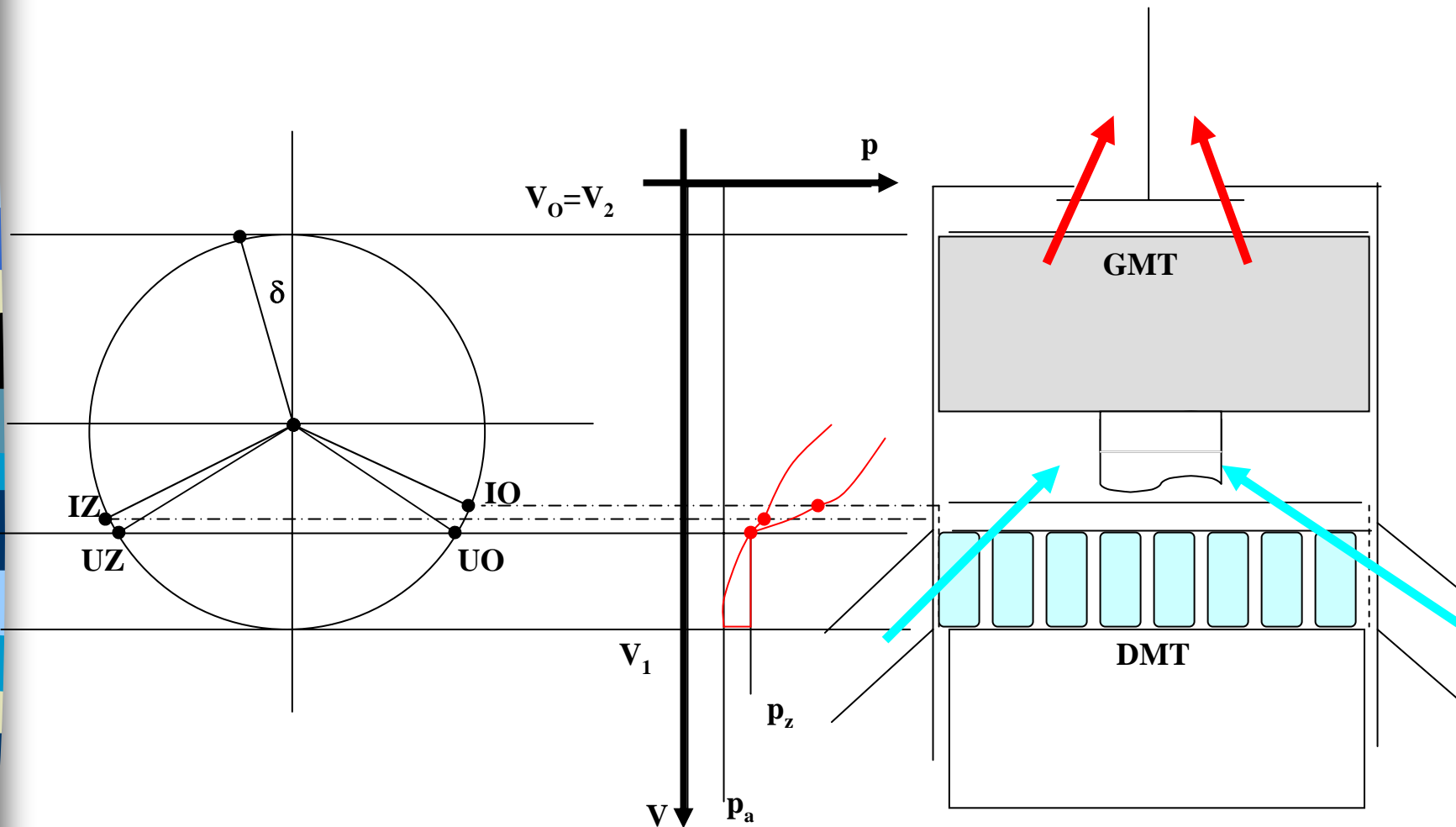



Motori – konstrukcija

- kućište (sporookretni)
 - cilindarski blok (plašteva)
 - stalak
 - temeljna ploča, uljna tava



Motori – konstrukcija

- stapni mehanizam:
 - temeljni ležaj
 - koljeničasta osovina
 - leteći ležaj
 - ojnica
 - križna glava, ležajevi, klizne staze
 - stapajica i stap – klip ²



Motori – konstrukcija

- cilindarski prostor
 - stap
 - košuljica cilindra
 - glava cilindra (isp.ventil², rasprskači¹²³,...)
- razvodni mehanizam
- sustav ispirnog zraka
- pomoćni sustavi (gorivo, ulje, k. zrak)

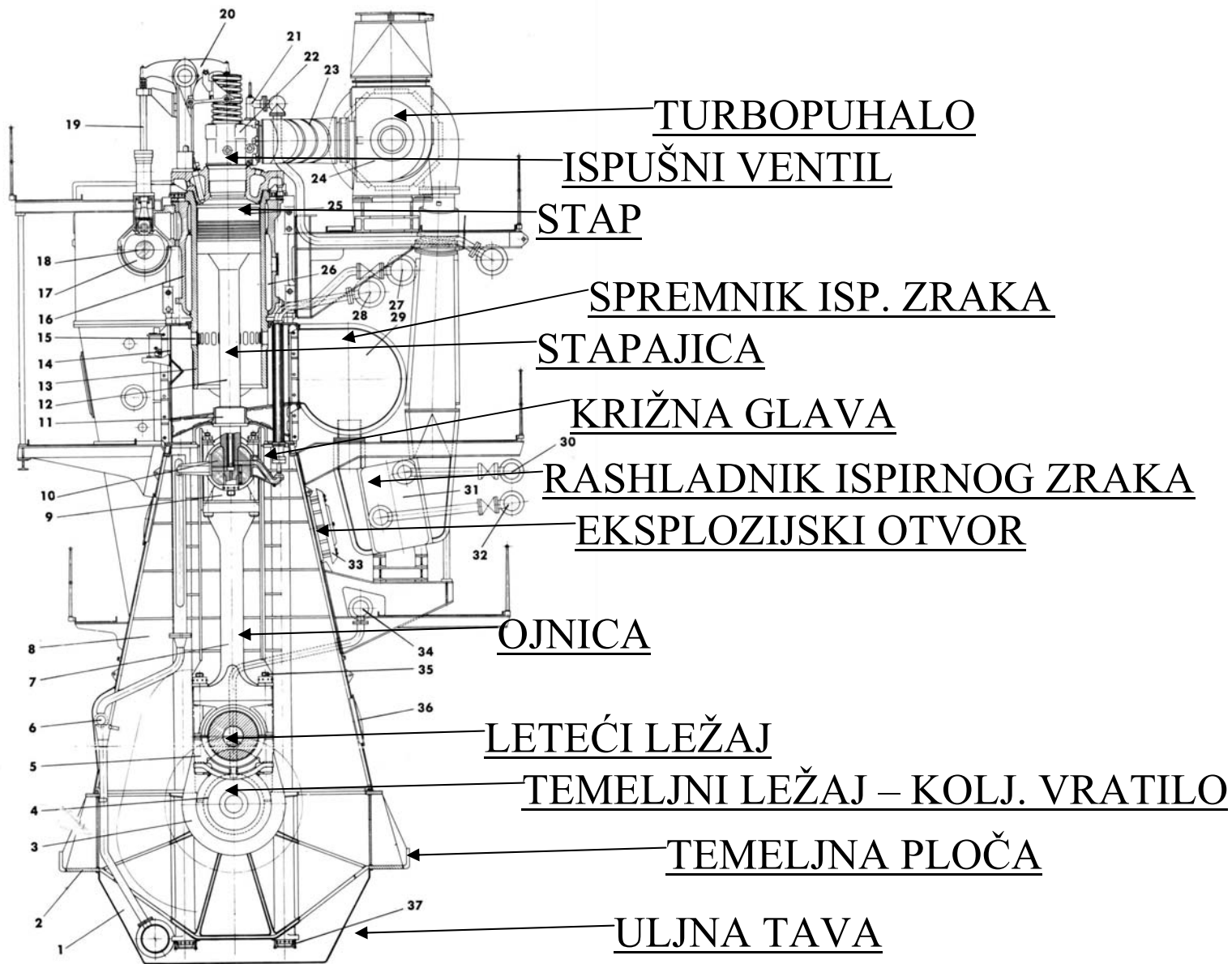

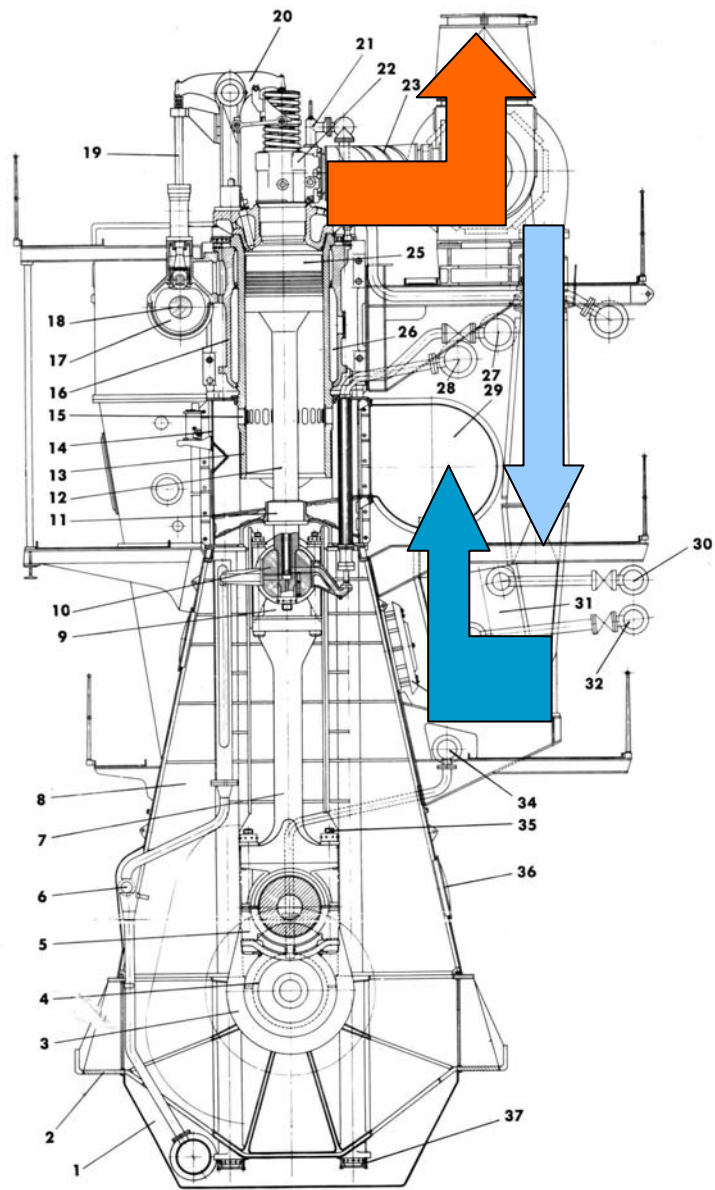

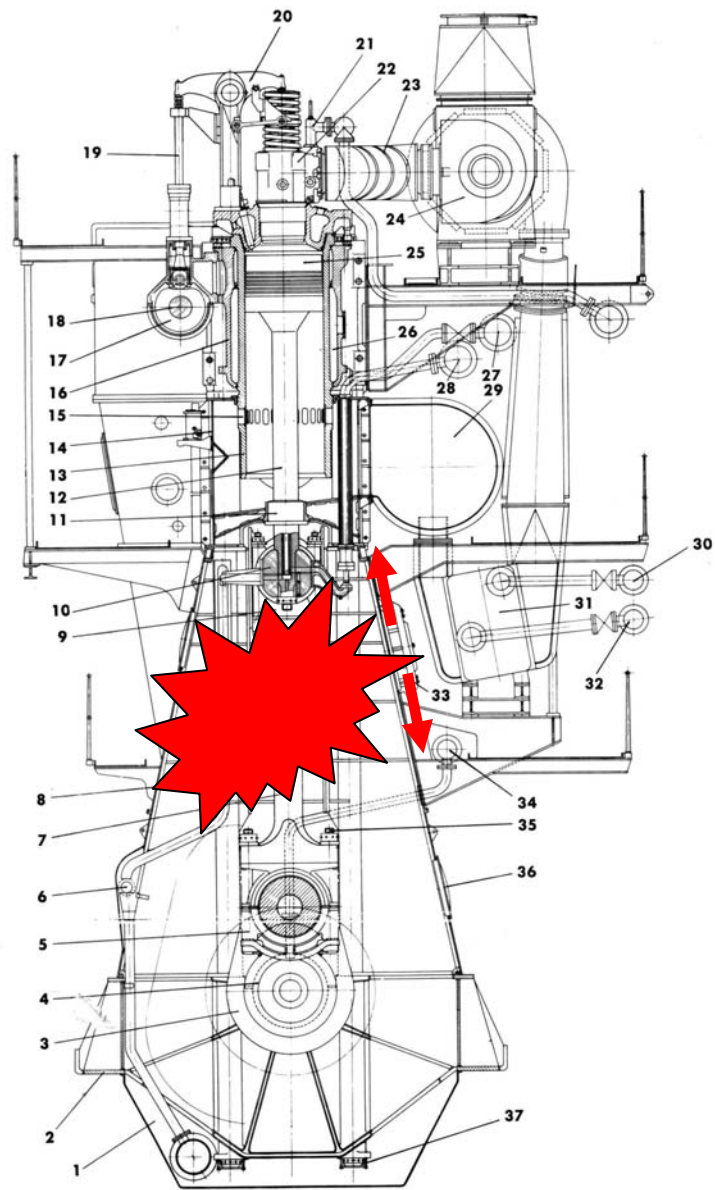

ZAŠTO?

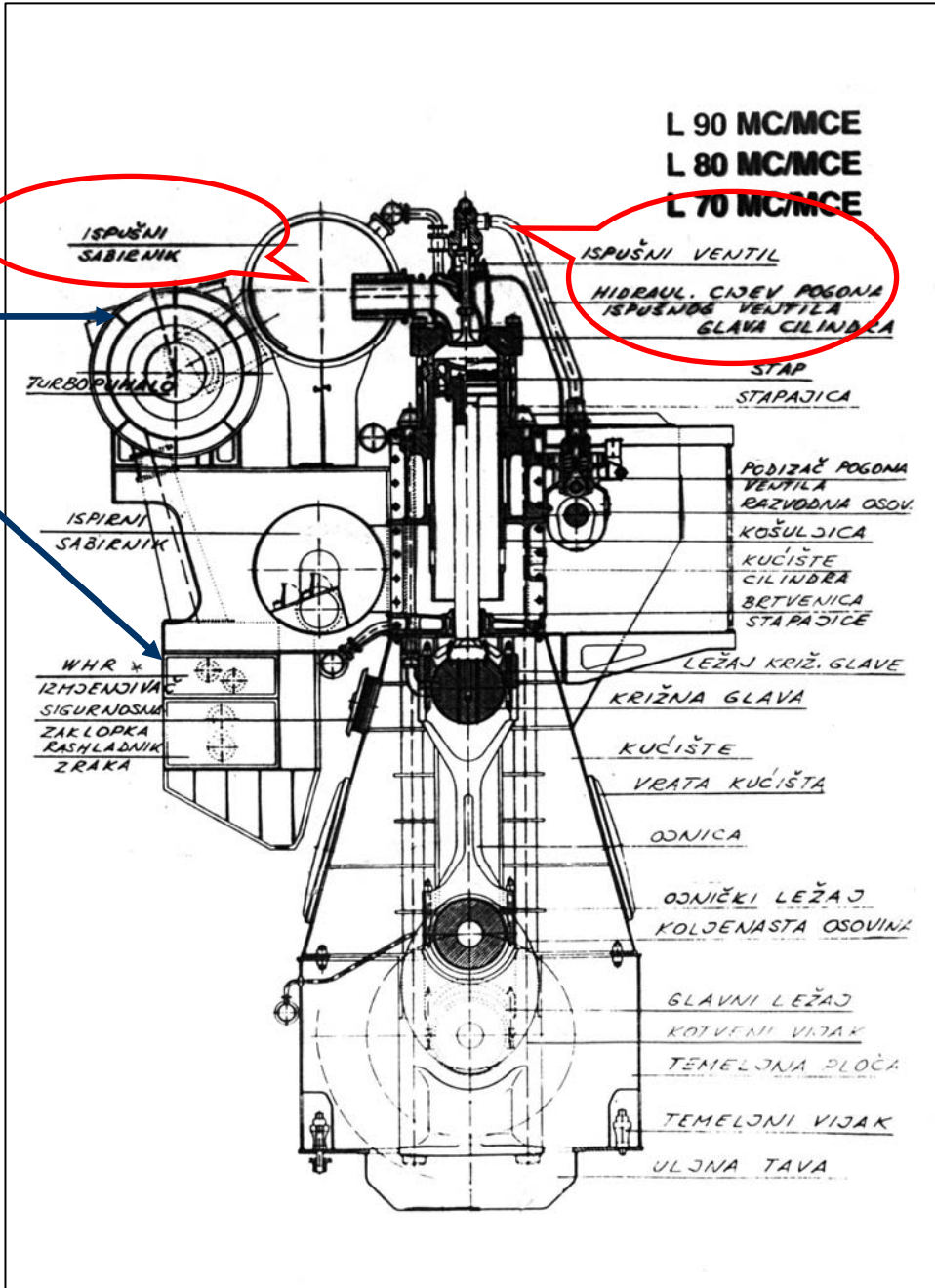

Ispiranje cilindra

- poprečno
- poprečno-povratno (okretno)
- uzdužno (istosmjerno)

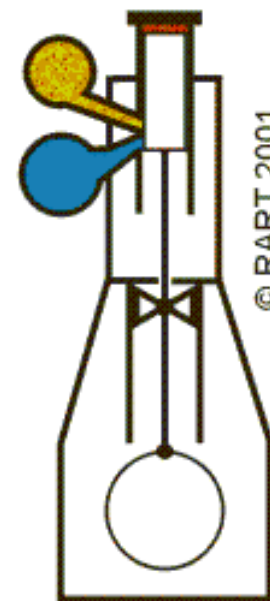

Bregasta

KOD MODERNIH MOTORA REGULACIJA JE ELEKTRONSKA – OČITAVA SE POLOŽAJ KOLJENIČASTOG VRATILA TE ELEKTRONSKI DJELUJE NA UBRIZGAVANJE GORIVA, ALI SE KORISTI ZA POGON VISOKOTLAČNIH PUMPI TE ZA HIDRAULIČKO OTVARANJE ISP. VENTILA



B:



Fuel Cam for unidirectional medium speed engine. The cam has fast lift for injection and a slow return to avoid shock loading



Inlet or exhaust valve cam for unidirectional medium speed engine. The cam has to open and close the valve smartly without shock loading

3 SERVOMOTOR

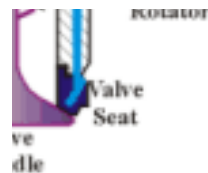

Ubrizgavanje goriva

Regulacija dobave goriva: zakretanjem klipa

- visokotlačni
- direktni
- vrtložni
- klipni
 - sa zakretanjem klipa
 - s preklapanjem ventila
- “common rail”

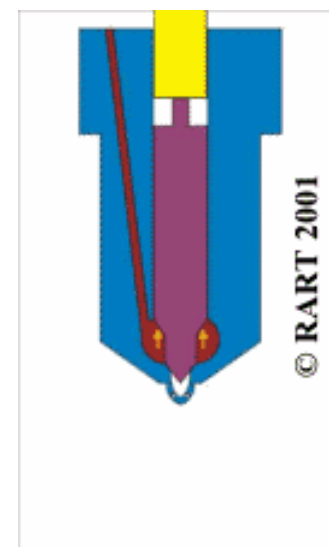
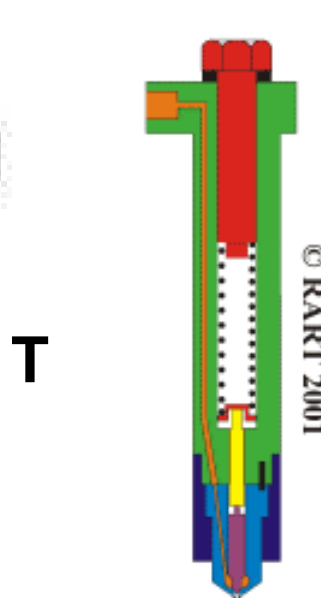
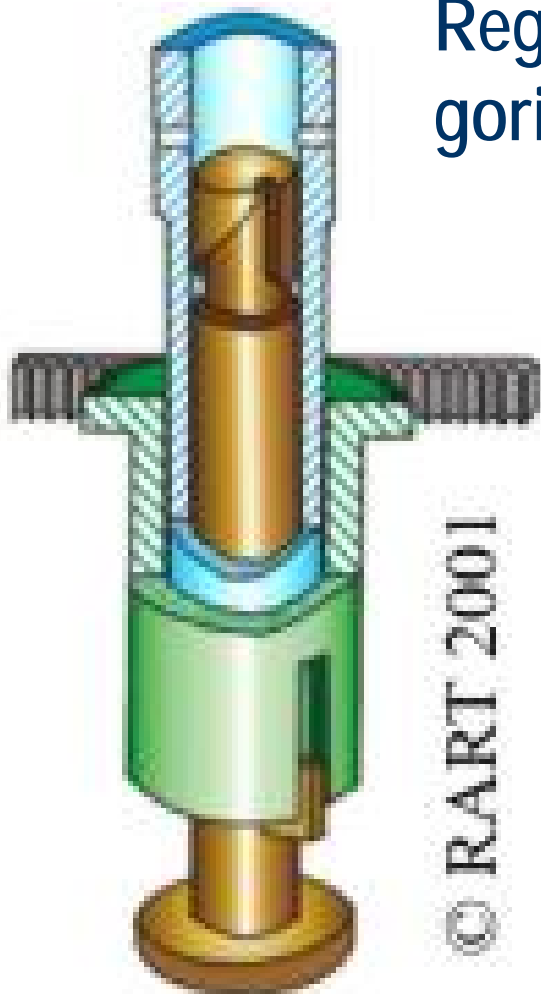

Ubrizgavanje goriva

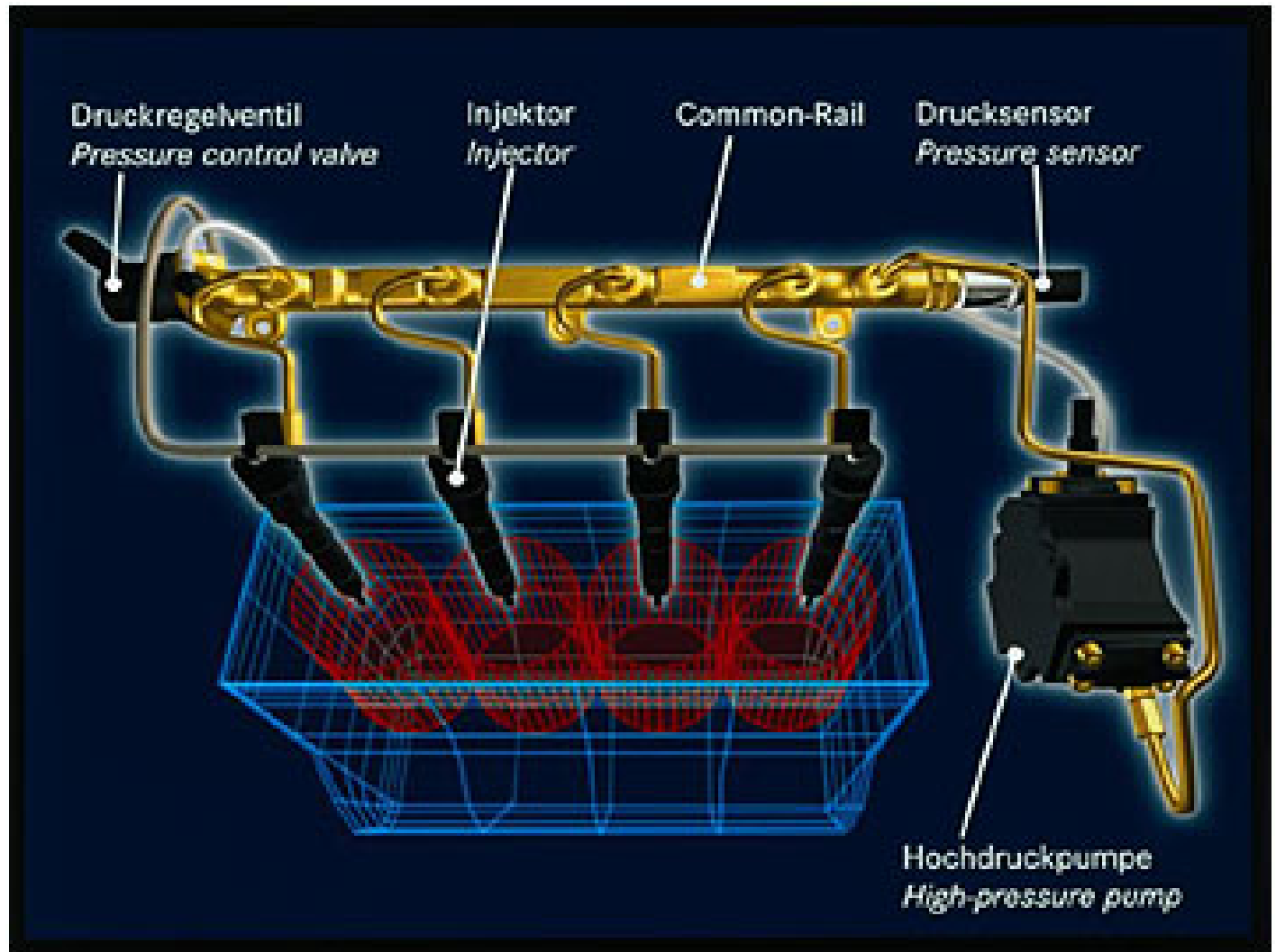



Podmazivanje

- manji motori privješene zupčaste p.
- veće snage – vijčane elektromotorne
- podmazivanje cilindara
 - “bućkanjem”, prskanjem
 - tlačno, lubrifikatori
- eksplozija uljnih para! (indikator)

Otvaranje uputnog ventila

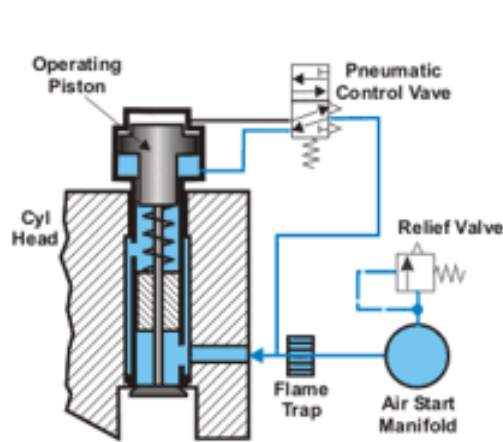

© 2003 RART marinediesel.co.uk

UPUTNI VENTIL
ZATVOREN

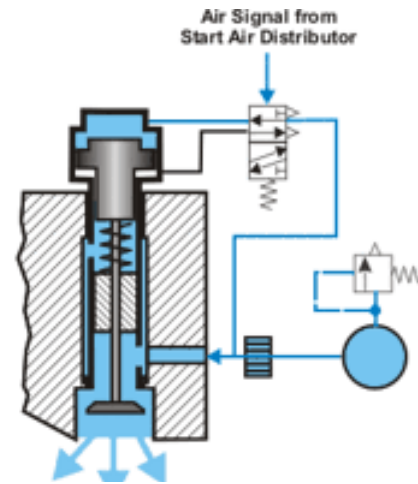

© 2003 RART marinediesel.co.uk

UPUTNI VENTIL
OTVOREN

Uputni (startni) zrak

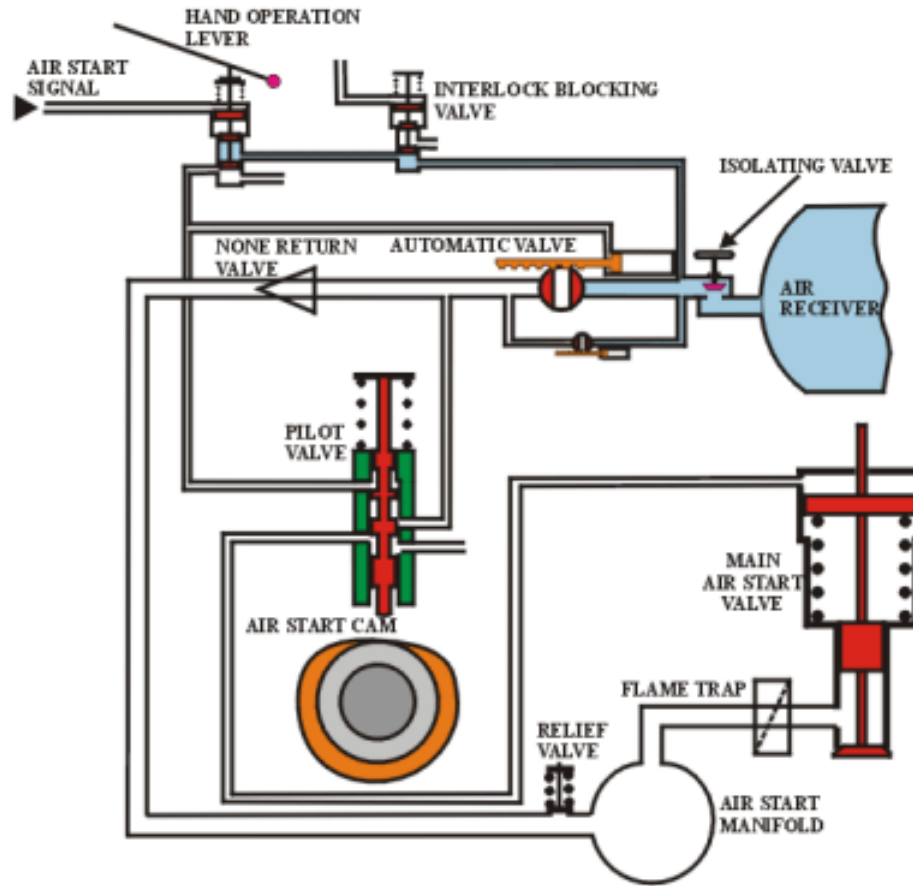

Prekretanje motora

© RART 2001

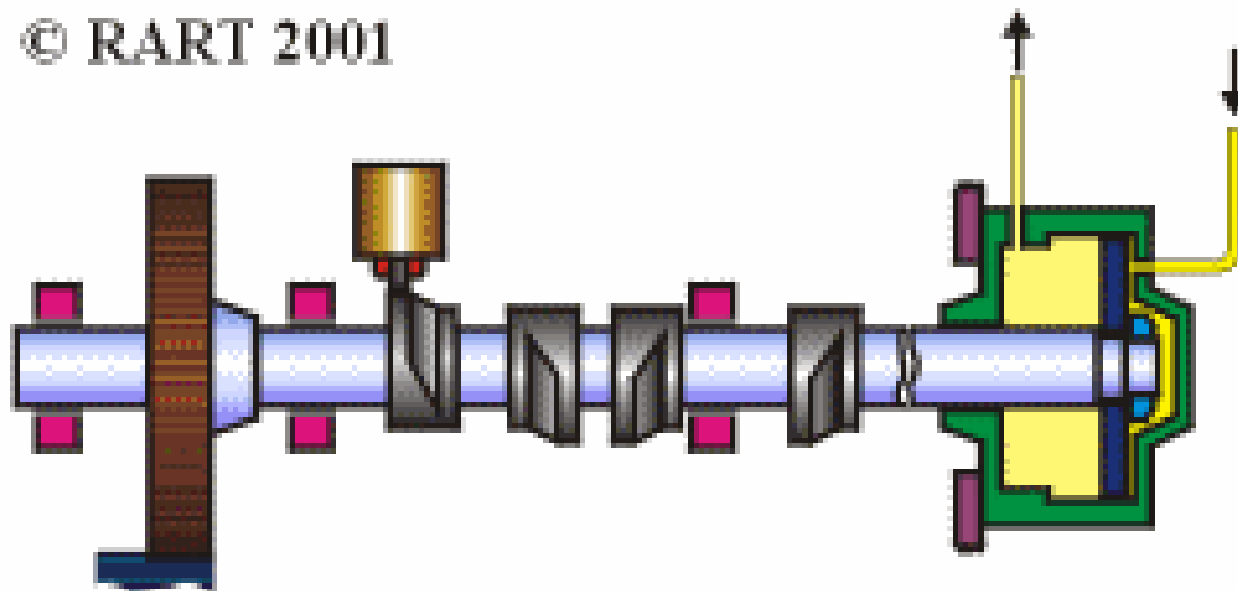

Regulator

- regulator broja okretaja
- “Woodward”
- (mehanički) hidraulički
- elektronski

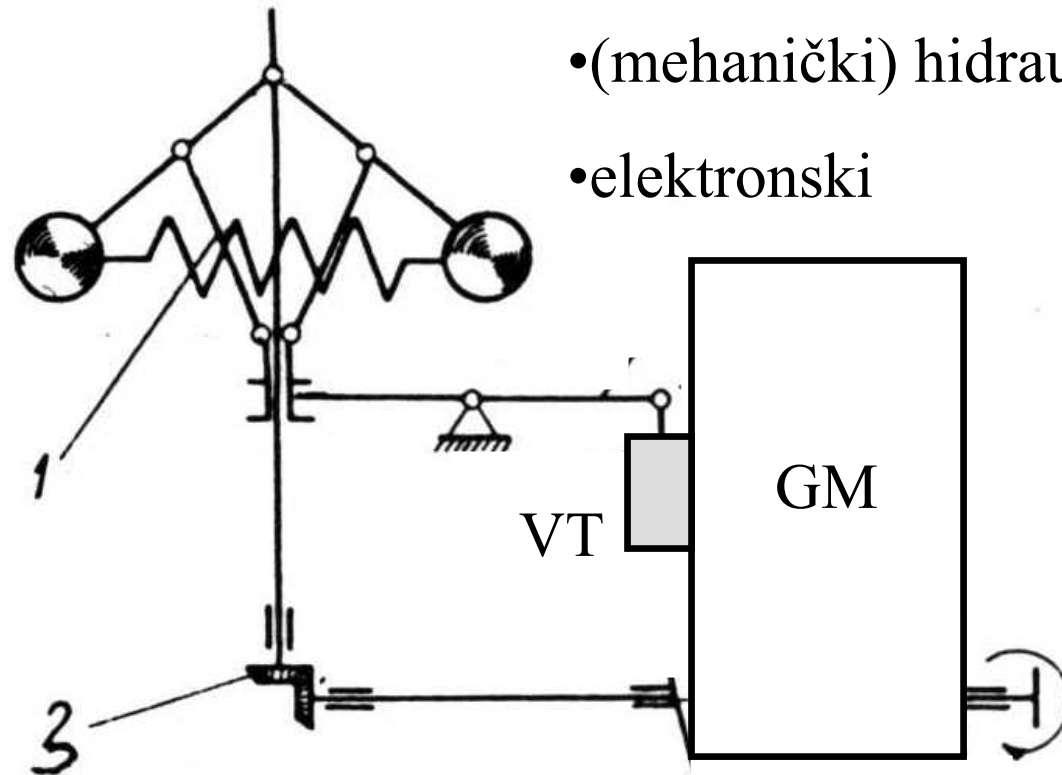

Razvoj sporookretnih motora

- povećanje stupnja iskoristivosti (>50%)
- usavršavanje procesa izgaranja u cilindru (rasprskачi, VT-pumpe, regulacija – common rail, ispiranje, aditivi i dr.)
- korištenje otpadnih toplina (PTO; KIP; VE; TO)
- smanjenje n_{min}
- smanjenje n_{nom} , čime se povećava η propulzije
- povećanje jedinične snage (12RTA96C \approx 90000 KS)
- automatizacija i dijagnostika
- smanjenje šuma i vibracija
- sustavi smanjenja količine emitiranih plinova štetnih za okoliš

Emisija plinova (IMO, prilog VI)

Air
7.8 kg/kWh



Fuel
171 g/kWh



Lubricating
oil
1.3 g/kWh

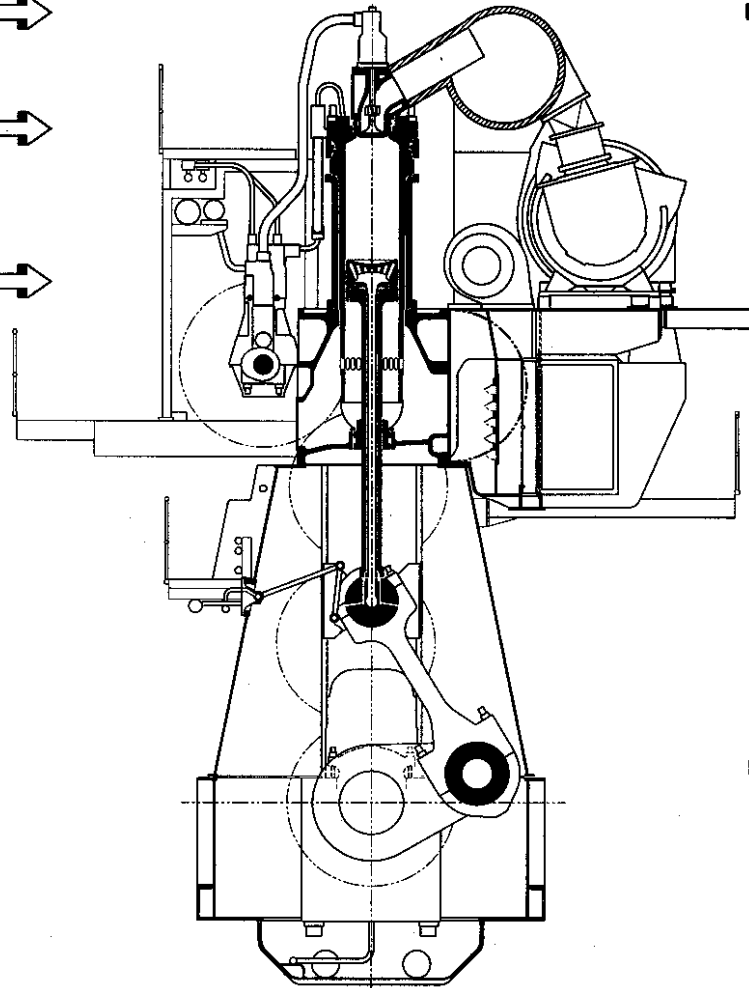

Exhaust gas
8.0 kg/kWh



N₂ 6.2 kg/kWh

O₂ 1.1 kg/kWh

CO₂ 0.5 kg/kWh

H₂O 0.2 g/kWh

NO_x 17.0 g/kWh

SO_x 13.6 g/kWh

CO 0.4 g/kWh

HC 0.4 g/kWh

Dust 0.6 g/kWh

UDIO

Power kW





Zagađivači

- NO_x (NO, NO₂, N₂O)
- SO_x (~s₀%, kisele kiše)
- CO
- HC
- (CO₂)

Požar u isp. prostoru

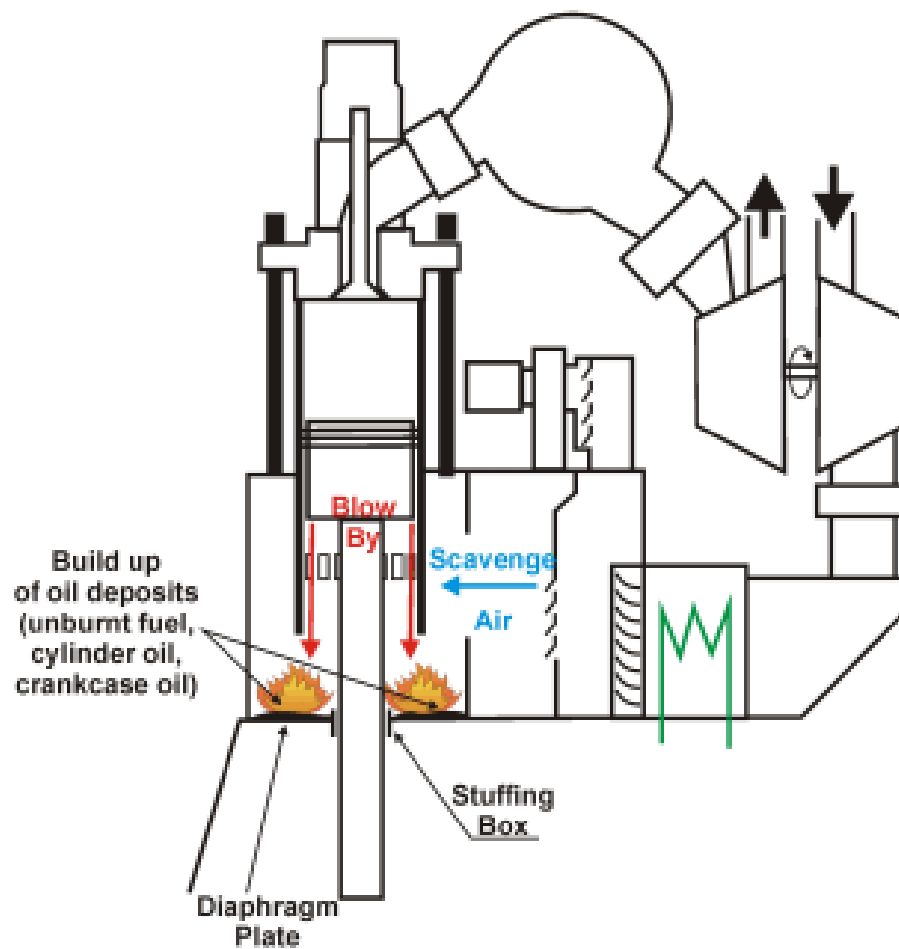

Uljne pare

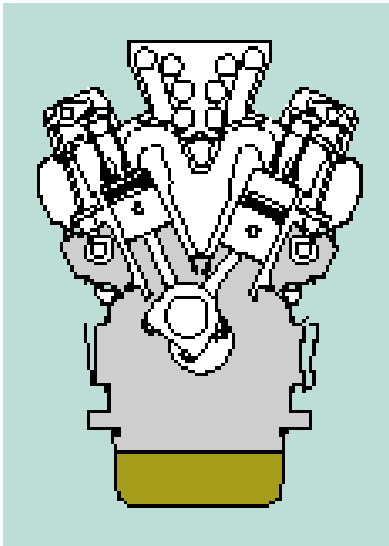

An unprotected engine – no Oil Mist Detector

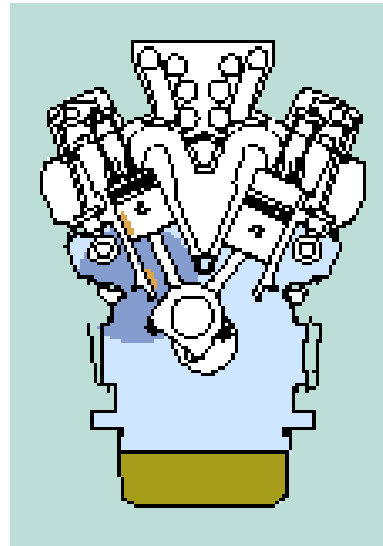

Build-up of oil mist due to 'hotspot' being undetected

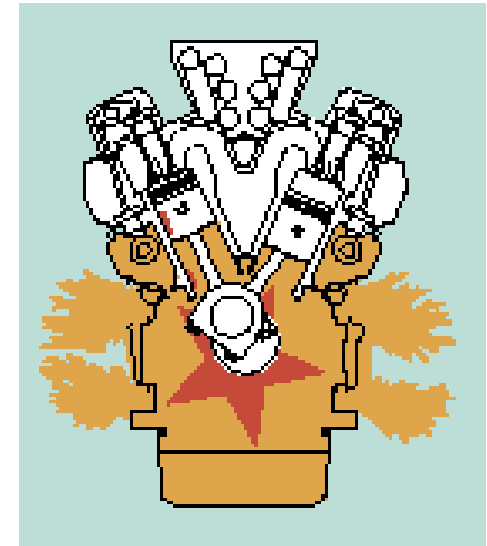

The possible result – ignition of oil mist causing a crankcase explosion

Gašenje

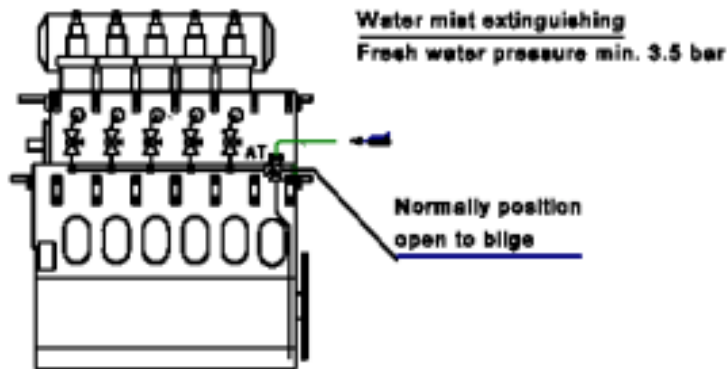
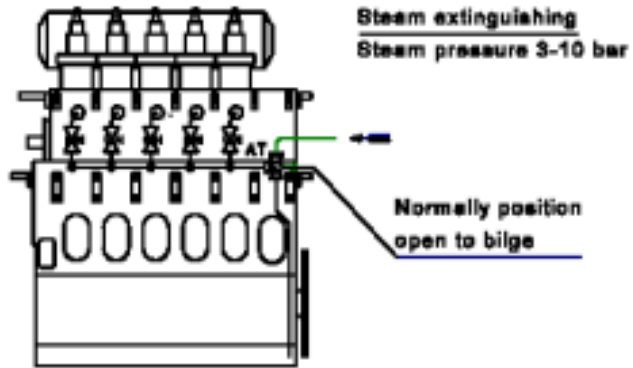

To prevent the fire from spreading to the next cylinder(s), the ball-valve of the neighbouring cylinder(s) should be opened in the event of fire in one cylinder

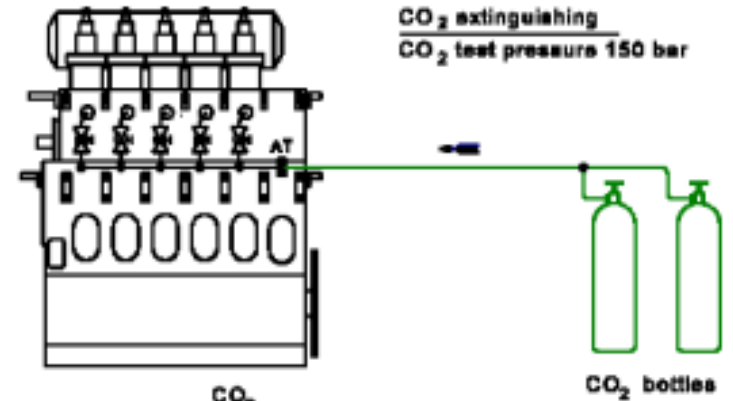

At least two bottles
In most cases
to extinguish
two or more bottles
extinguish fire





Mjerenje potrošnje goriva

- mjerač protoka
- sondiranje tankova
- prostorni dijagrami (za D_w , v i T_{sr})
- dijagrami motora (garantirani SFOC)

Priprema GM za pogon

- predgrijavanje motora VT vodom

- predpodmazivanje

- provjera tlaka sta

- korm. uređaj

- reduktor

- propuhivanje cilind

- propeler

- zakretanje ili zrak

- ulje statvene cijevi

- priprema goriva (

- cirkulacijska pumpa KIP-ove

- pomoćna puhalo (automatski rad)

- provjera prekretanja

- priprema sustava rashladne vode

- startanje s $\approx 40\% n_{nom}$ (SLOW)



“Automatika” GM

- upravljanje GM u plovidbi
- upravljanje GM tijekom manevriranja
- daljinska i automatska kontrola/regulacija parametara u pogonskim sustavima glavnog stroja
- indikacija parametara
- alarmiranje i zaštita
- "noviji" sustavi izvršavaju i funkciju dijagnostike kvarova (FAKS - fault avoiding knowledge system, CAPA - computer aided problem analysis)

Telegraf

- BCR, ECR, lokalno
- prebacivanje odg. kod istog položaja
- ECR – prednost
- “stand by”, “finished with engine”

dead slow	$30\% n_{nom}$
slow	$40\% n_{nom}$
half	$50\% n_{nom}$
full	$70\% n_{nom}$
full sea speed	$100\% n_{nom}$

Kvar ispušnog ventila ili...

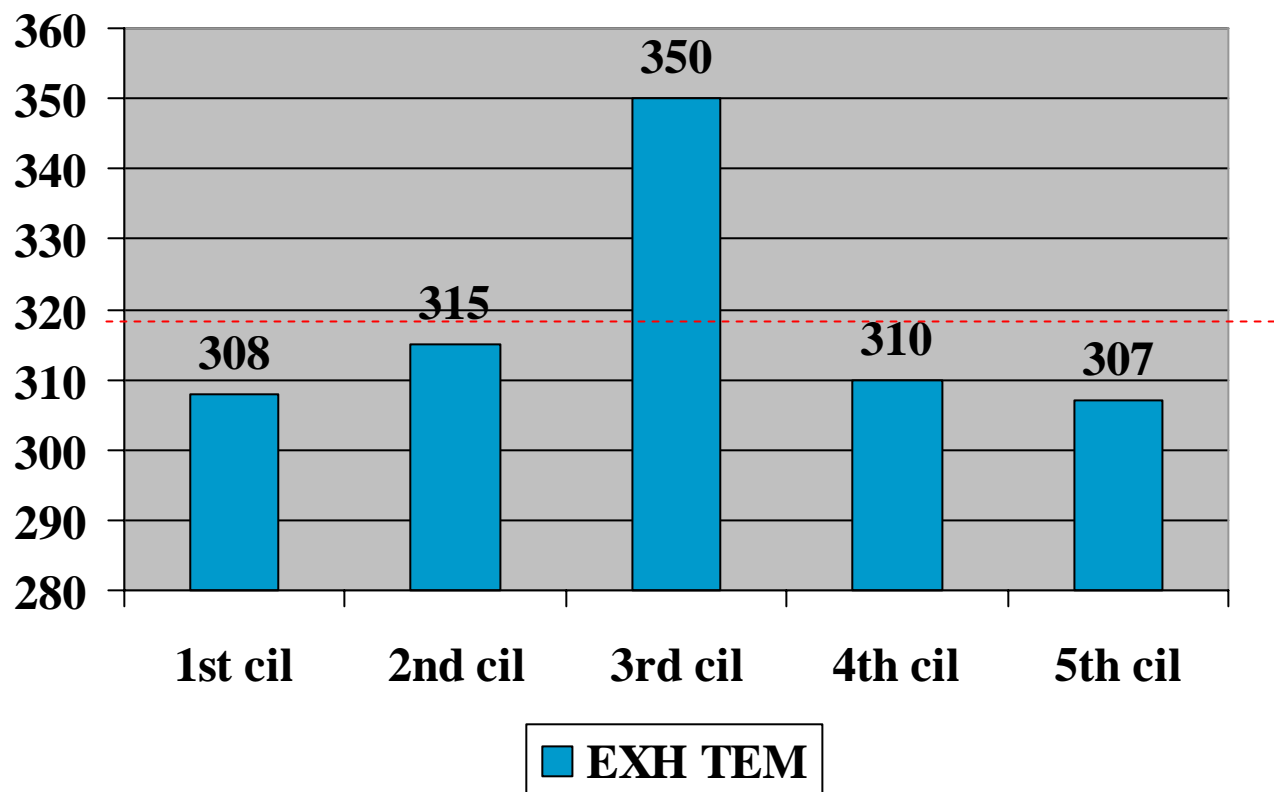



Ostalo

- prekretanje
- “crash manoeuvre”
- fina regulacija n
- zaštita:
 - “SLOW DOWN” i “SHUT DOWN”
 - “overspeed”
- dijagnostika kvarova